

# FEASIBILITY OF WIRELESS SENSORS FOR HEALTH MONITORING IN SMALL INDUCTION MOTORS

Xin Xue, V. Sundararajan

Department of Mechanical Engineering, University of California, Riverside

**Abstract:** Wireless sensors are an attractive, flexible, low-cost and low power option for condition monitoring for small induction motors. Motors present a harsh environment for wireless sensors because the electromagnetic fields present in the motor and the metal enclosures can corrupt the data by interfering with the electronics of the sensor node and/or with the wireless communication. This paper investigates the characteristics and performance of wireless sensors for application in small induction motors. The parameters that are studied are: 1. The fidelity of the data acquisition as determined by comparison with wired sensors; 2. The reliability of the communications as a function of distance, spatial position and battery life of the sensor. This reliability is measured as the percentage of successfully delivered data packets. The experiments employ vibration sensors placed inside the motor enclosure on the stator and on the motor shaft. Each sensor is interfaced to a wireless node that possesses communication and computational capability. The transmitted data is collected by a base station located outside the motor. The results show that it is possible to obtain data with very little loss or corruption depending upon the location of the sensor nodes and the base station. For stationary sensor nodes, the placement of the receiving base station must be carefully determined to avoid fading effects. However, the quality and reliability of the data collected by wireless sensors are comparable to those collected by wired sensors. The results also show that battery life is a limiting factor in the use of wireless nodes. This limitation can be overcome by a combination of on-board information processing and energy scavenging.

Key Words: Condition Monitoring, Wireless Sensor Networks, Induction Motors

## I. INTRODUCTION

Condition monitoring provides information on the health of industrial machinery and is widely being adopted as an alternative to the more conventional preventive and breakdown maintenance strategies. Measurements and monitoring of parameters such as vibration, temperature, noise level and power consumption can help to detect the

trends of developing faults and determine the sources of problems. This can be used to schedule maintenance more effectively by avoiding unnecessary maintenance and by preventing catastrophic failures [1].

At present, most of the sensors are physically wired. The wires provide both power and communications paths. However, in many applications, wired sensors are impractical or inconvenient. For example, they are difficult to mount on rotating machinery or high temperature applications. In these situations, wireless sensor networks provide a possible solution. These networks can be used in remote locations and also offer inexpensive and flexible installation.

In contrast to conventional condition monitoring of electrical machinery that measure current or vibration signals outside the motor, wireless sensors provide access to useful signals inside the motor where the phenomena responsible for failure occur. These sensors are capable of not only sensing, but also of processing, storage and eventually communication. This paper studies the feasibility of wireless sensor nodes inside the motors using current technology and evaluates the data acquisition and transmission performance of these nodes. Wireless sensors bring up several issues that need careful study and experimentation. The quality of wireless communication depends on the environment, the part of the frequency spectrum under use, the particular modulation schemes under use, and possibly the communicating devices themselves [2]. Wireless receptions change with slight spatial displacements and also may vary over time. Multi-path interference cause signal nulling, signal amplitude increasing or decreasing, and data corruption. Many of the current sensor platforms use low-power radios which do not have enough frequency diversity to reject multi-path cancellation. In addition, when signals are sending from the transmitter inside the motor, the motor enclosure may block the signal but the extent is unknown. Although the induction motors are designed to have minimum field leakage, there is still some fringing field around the windings. This field may affect the operation of the sensor and the wireless communication. Finally, wireless sensors are conventionally operated on batteries that have a finite life. Thus the quality of data acquisition and

communication can deteriorate as the battery becomes weaker.

In this paper, we study packet delivery performance at the communication stack and the data fidelity of the wireless accelerometer sensor that is used in industrial applications for vibration analysis. Some sensitive patterns of faults need frequency analysis with data acquired at a higher sampling rate which in turn implies higher transmission rates. Packet delivery performance is important since it translates to data completeness. With such a high sampling rate and transmission rate, the battery life is reduced. We also inspect the packet delivery performance during the whole battery lifetime. Compared with wired accelerometers, wireless sensor has limited sampling rate and data precision. A comparison between wireless and wired accelerometer measurements answers the question whether the data collected from the wireless sensor is reliable and useful.

## II. RELATED WORK

There is not much work that has evaluated packet delivery performance on ad hoc or infrastructure based wireless sensor networks (WSN) in industrial environments. Zhao et al. [2] describe results from three different environments on a medium scale (up to 60 nodes) ad hoc WSN. The environments they studied are office building hallway, a spacious parking lot and a local state park. Ganesan et al. [3] studied a large-scale (approximately 180 nodes) testbed grid on an unobstructed parking lot. Their research focuses on the loss and asymmetry of packet delivery at both the physical layer and the medium access control (MAC) layer. In this paper, our study of packet delivery performance is focused on the harsh industrial environment which demonstrates that wireless sensors are capable of transmitting useful data from an induction motor.

Tsai et al. [4] study the feasibility of an In-car WSN and test the wireless communication channel between the base station and a sensor placed under the engine compartment. Their statistical study shows that the In-the-Engine-Compartment channels can satisfy the requirement of up to 98% packet reception rate. Paselli et al. [5] designed a modular wireless sensor node for machine control applications. It demonstrates the feasibility of wireless communication between fixed and moving parts of industrial machines in the distance of 1.5m. However, the power consumption (3W) is very high. Rahimi et al. [6] study the feasibility of extending the lifetime of a wireless web-cam network in building by exploiting mobility. In their system, a small percentage of network nodes equipped with solar cells are autonomously mobile, allowing them to move in search

of energy, recharge, and deliver energy to immobile, energy-depleted nodes assuming the static nodes are rechargeable.

There are already some existed industrial applications reported using wireless sensors. Jemielniak [7] reported a wireless acoustic emission sensor commercially available from some companies such as ARTIS [8], Nordmann [9], Prometec [10]. It is implemented in a machine tool condition monitoring application. The wireless AE sensor consists of a rotating sensor and a fixed receiver with an airgap of only 0.6mm. Discenzo [11] described a pump condition monitoring application using self-powered wireless sensors. Shen et al. [12] and Bonivento et al. [13] have described their design flow of industrial applications of WSN using commercial nodes. Shen targets the application in industrial process monitoring and controlling. Bonivento presents a case study of a control application for manufacturing plants. In this paper, we present an application of industrial WSN by investigating the feasibility of wireless sensor nodes inside small induction motors.

## III. METHODOLOGY OVERVIEW

### 1. Equipment and Instrumentation

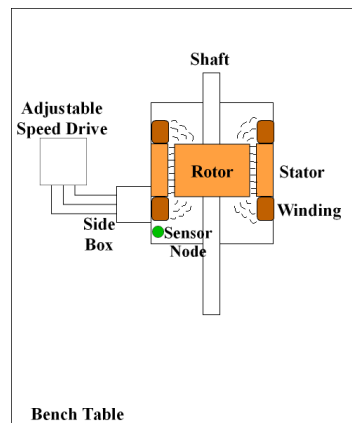
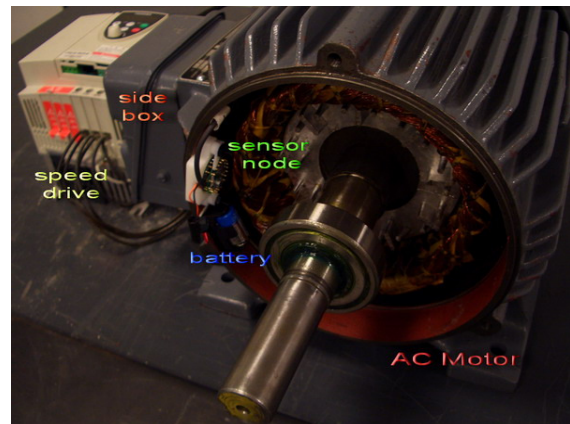

Fig. 1 Experiment Set Up

(a) Photo (above)  
(b) Diagram (left)

(a) Motor: A three-phase induction motor from Newman Electric Motors, Inc. stands on a strong-hold steel workbench table. The 1 hp induction motor is connected to an adjustable speed drive from Toshiba International Corporation. The running speed ranges from 0 to 900 rpm and can be adjusted by the speed drive. Figure 1 shows the placement of a wireless sensor node inside the induction motor. The diagram shows the leakage magnetic field around the windings outside the stator core. The sensor node inside is exposed inevitably in the fringing field. The dynamic field when motor running is up to 70 gauss in the peak close to the core edge measured by the hall-effect sensor [14] (in comparison, the maximum field strength of the earth is about 0.6 gauss [15]).

(b) Sensor: Three vibration sensors are mounted on the side-box by the double-sided tapes. Vibration specifications are usually expressed in terms of acceleration peak for sine and acceleration RMS for random vibration. Spectral content such as power spectral density curve is used to describe random vibration specifications. The vibration spectral content is compared between these three sensors.

(c) Wireless Sensor System: A wireless sensor system consists of at least one sensor node and a base station. A sensor node is comprised of a sensor mote and a sensor board. Figure 2(a) shows the sensor node and its casing. Figure 2(b) gives the corresponding block diagram. The sensor mote (MICA2DOT) hosts an Atmel128L CPU that runs the Tiny Operating System (TinyOS). The operating system executes programs independently written in the programming language nesC [16]. This microcontroller has its maximum clock frequency of 8 MHz and provides the following features: 128K bytes of In-System Programmable Flash with Read-While-Write

capabilities, 4K bytes EEPROM, 4K bytes SRAM, An 8 channel 10-bit analog to digital converters (ADC), Real Time Counter (RTC), etc. An external flash memory of 512K bytes is used to store measurements. The radio center frequency is 916MHz. The data transmission rate is characterized at 38.4 kbits/s. Typically, the power for computing is 24mW, the transmitting power is 81mW and the receiving power is 30mW.

A sensor board is a PCI board that can be connected to the mote. The design of the sensor board depends on the type and the number of sensors needed. The sensor node and the programming boards used in the experiment here are commercially available from Crossbow Technology Inc. Figure 2(a) depicts the sensor node in a plastic casing. A magnet is integrated to the bottom layer of the sensor node case. The sensor board and mote is about 25 mm in diameter. The measured data is transmitted from the sensor node and is received by the base station. The base station consists of one sensor node and a programming board. The programming board is connected to a computer by a serial cable. Figure 2(c) shows the block diagram.

(d) Wired Sensor Systems: Wired sensors and data acquisition systems are used to study the fidelity of wireless sensor data. One of the wired accelerometers (from Crossbow, Inc), is a one directional sensor with  $\pm 4g$  measurement range and  $500 \pm 15 mV/g$  sensitivity. Another accelerometer chip has better accuracy than the one used in wireless sensor board. Its evaluation board is from Analog Devices, Inc. The measurement range is  $\pm 5g$  and its sensitivity is  $174 \pm 17 mV/g$ . The accelerometer chip on the wireless sensor board has its measurement range of  $\pm 2g$  and sensitivity of  $167 \pm 27 mV/g$ .

Fig. 2 Wireless Sensor Components



(a) Quarter Size Mica2Dot Sensor Node and Casing

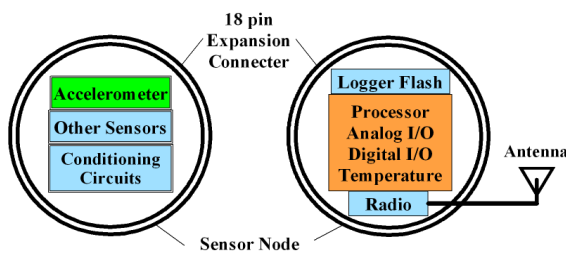

(b) Mica2Dot Sensor Node Block Diagram

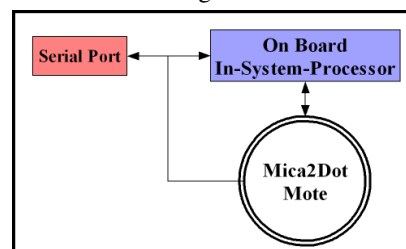

(c) Base Station Block Diagram

## 2. Operation of the Sensor Node

Figure 3 shows the packet construction and packet transmission flow. The sampling rate is set to 100 Hz. Data is collected for 2 seconds continuously and stored in a buffer. Then all the packets are sent to the base station one by one as fast as possible. When all the packets are sent out, the sensor node starts to collect data again. Each measurement data uses 2 bytes of memory (hence 200 bytes/s). In the data area for each packet, 20 bytes is used for collected data, 2 bytes is used for time stamp, and the last byte is used to mark the CRC checking results. The packet ID number and the time stamp are used to compute the percentage of packets received.

To send a packet, the application layer (in our case, this will be the data acquisition and processing application that runs on the sensor nodes) invokes the communication stack with the packet to be sent and the

address of the destination node of the packet. After performing medium access control (MAC) to ensure that there is no other communication in progress on the wireless channel, the MAC layer begins sending the packet one byte at a time. Each byte is coded and sent over the channel. Simultaneously, a cyclic redundancy check (CRC) code is computed over the entire packet and is appended to the transmission. The receiver receives the coded bytes and decodes them, correcting any single bit errors and flagging double bit errors. When the entire packet has been received, a CRC code is computed by the receiver on this packet and is compared to the CRC that was computed and transmitted by the sender. If the two do not match, the packet is rejected as spurious. CRCs are popular because they are simple to implement in binary hardware, are easy to analyze mathematically, and are particularly good at detecting common errors caused by noise in transmission channels.

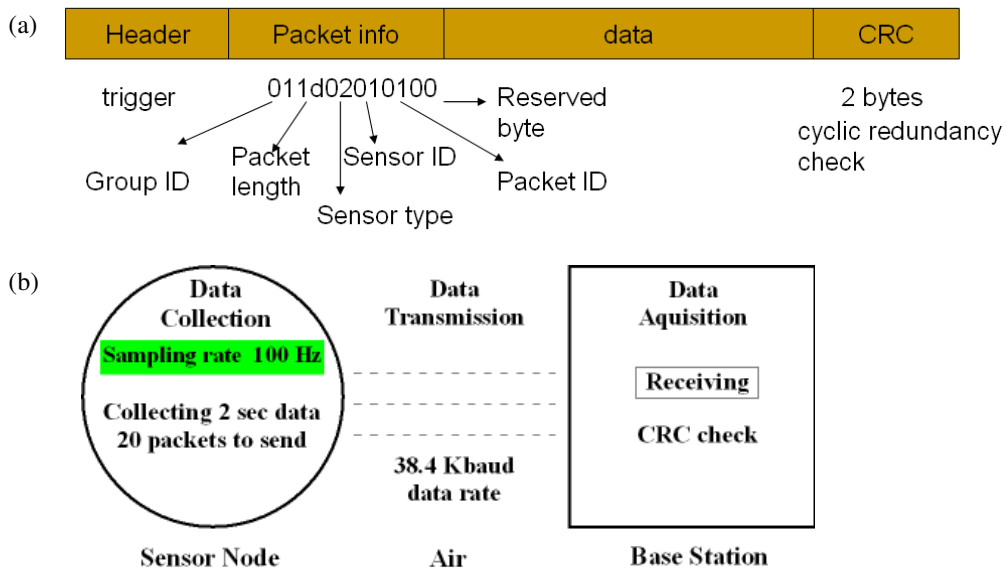

Fig. 3 (a) Packet Construction (b) Packet Transmission Flow

## 3. Experiments

### A. Packet Delivery Performance

The most basic aspect of wireless communication is the packet delivery performance. In order to characterize the packet delivery performance, we investigate both the packet loss rate (the fraction of packets that were transmitted within a time window, but not received) or its complement, packet reception rate, as well as the packets that fail the CRC checks. Therefore we measure two

metrics: 1) percentage of packets received; 2) percentage of packets without error.

The motor enclosure is not symmetric with respect to the shaft. In Figure 1, a side-box is on the left side where the winding terminals usually come out and connect with the power source. There is always some part (at least a hole) not sealed with metals. In fact, industrial totally enclosed small motors are not really completely enclosed/sealed. A radio frequency signal encounters objects that reflect, refract, diffract or interfere with the signal and can be then received outside. In order to study the spatial

characterizations, we use three base stations (see Figure 4) to receive the signal from three different directions and vary with the distances. The sensor node is located at the stator of the motor or on the shaft. We also check the

packet delivery performance along the battery lifetime in the base station 2 direction with the sensor node on stator.

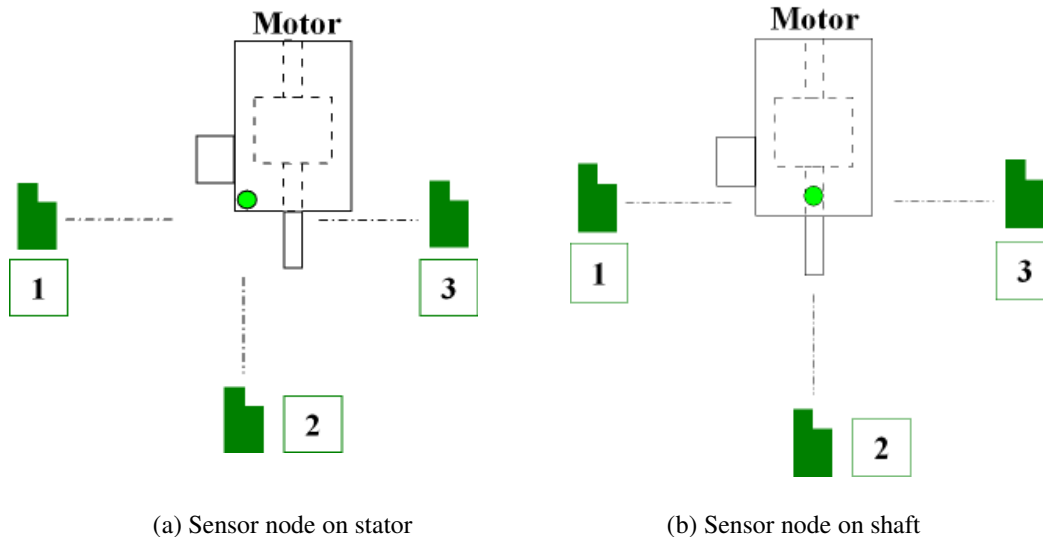

Fig. 4 Three Base Station Set-up

Experiments show that there are points where there is zero or faint signal reception. This is due a phenomenon called fading effect. Fading is caused by interference between two or more versions of the transmitted signal which arrive at the receiver at slightly different times. These waves, called multi-path waves, combine at receiver antenna to give a resultant signal which can vary widely in amplitude and phase, depending on the distribution of the intensity and relative propagation time

of the waves and the bandwidth of the transmitted signal. Signal nulling occurs when the reflected waves arrive exactly out of phase with the main signal and cancel the main signal completely. To investigate the fading phenomenon, we move the base station in steps of 1cm on either side of one null signal point. The base station position is showed in figure 5. We also check the same locations for the sensor node on shaft.

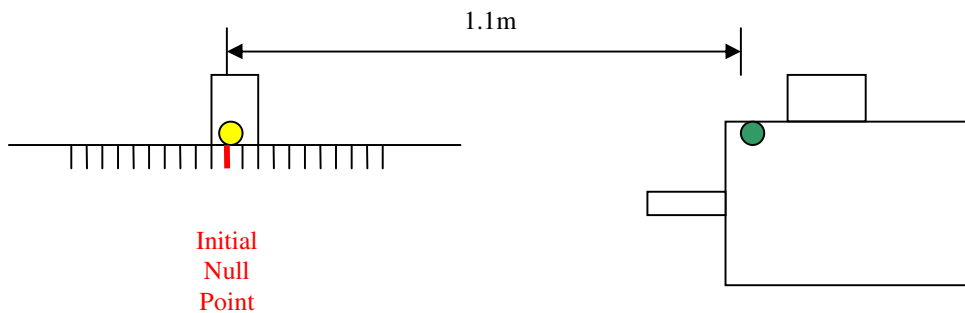

Fig. 5 Fading Effect Observation

### B. Data Fidelity

In order to monitor the motor health, the vibration frequency spectrum needs to be monitored. The wireless

sensor and two wired sensors are installed on top of the side box in the same direction. All of them are mounted by a double sided tape. With the motor running, these sensors should detect the same frequency contents. This setup can not be done inside the motor because the

curvature of the motor housing makes it very hard to install three sensors at the same position. Instead, we use each of the wired sensor set up with the wireless sensor at the same position but one inside and one outside (Figure 6).

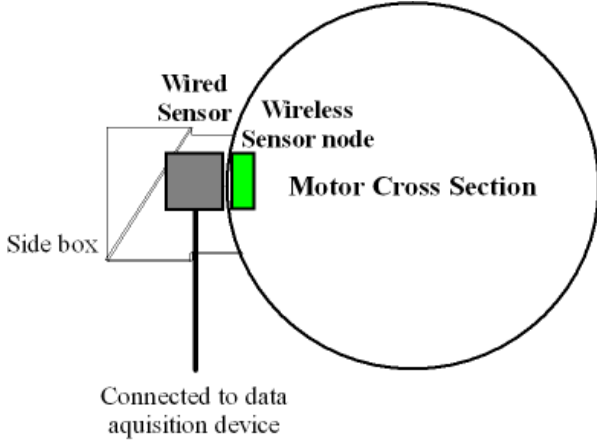

Fig. 6 Inside/outside sensor set-up

#### 4. Results and Discussion

##### A. Packet Delivery Performance

The first experiment is to study the spatial characterization of packet delivery performance. The reception rate of three base stations (see Figure 5) is shown in figure 7. The total height of the bars is the percentage of packets received. The green bar represents the percentage of the packets that have CRC ok. When the sensor node is installed on the stator, the reception rate of base station 1 is above 98% until as far as 3 meters away from the sensor node. It seems that there is no null point when the sensor node is on the shaft.

The second experiment is for 42 hours to investigate the time based difference of packet delivery performance. Figure 8 shows two base stations' packet delivery performance in the direction of base station 2 in figure 4. The packets are collected every 30 minutes before 1500 minutes and every hour after that. The closer base station (approximately 0.5m) shows very good data reception rate in the time span of continuously running for 39 hours. The farther base station (approximately 1.35m) shows a clear degradation of the CRC passed rate in the first 10 hours. The reception rate keeps above 80% until the last 3 hours of operation. The CRC passed rate in figure 7(b) got better performance before the battery died. It is probably because of the variance of the environment.

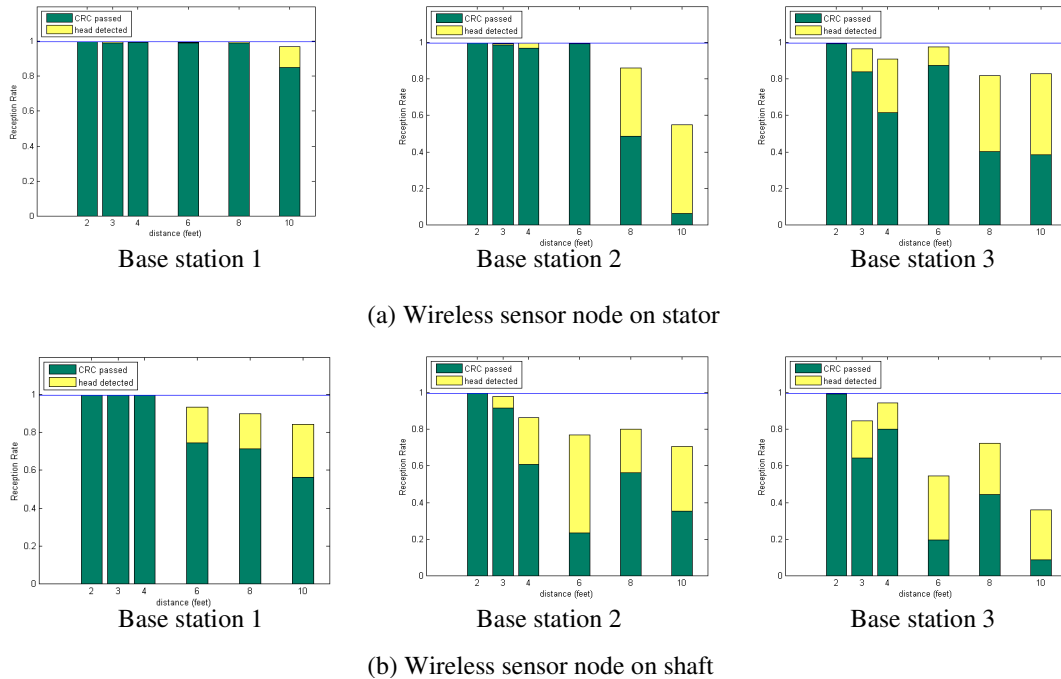
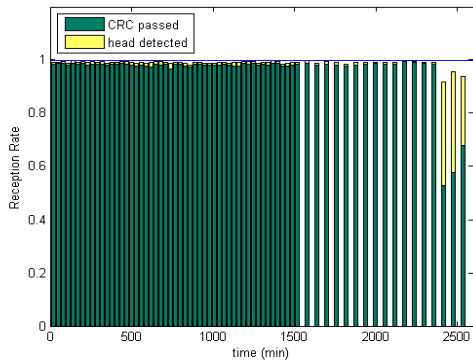
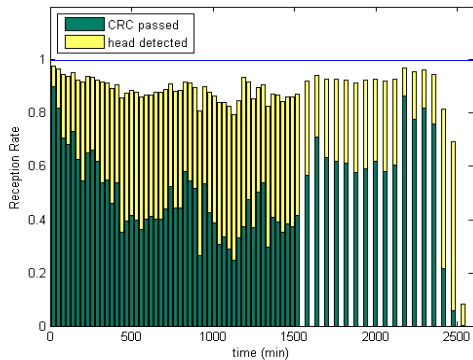

Fig. 7 Spatial Characterization

During the experiments above, we found there are always some null points that no signal can be received at particular position. These null points are due to fading in wireless communication and will affect the packet delivery performance and eventually the data quality. To explore further, the base station was placed at a point of low reception. This point was approximately 1.1m from the sensor node as seen in Figure 5. The base station was then moved in steps of 1 cm in each direction. Figure 9 shows the results of packet delivery performance besides this null point. As can be seen there are some other null points found in the position closer to the sensor node



(a) Base station at 0.5m  
Temporal characterization



(b) Base station at 1.35m  
Temporal characterization

Fig. 8 Time Based Difference

### B. Data Fidelity

In order to investigate the data fidelity of wireless accelerometer, two wired sensors are used to compare with the wireless sensor. One wired sensor and its data acquisition board is from Crossbow, Inc. This acceleration has a sampling rate about 180Hz, The other wired sensor is an evaluation board with the

because of the multi-path effect in the indoor environment. The sensor platform uses low-power radios which do not have enough frequency diversity to reject multi-path propagation. Thus the position of receiving node outside the motor should be carefully chosen when the sensor network is set up. At the same location, Figure 9 (b) shows if the sensor node is installed on the shaft and rotates when the motor is running, the losses are relatively uniform because the mobility of the sensor node provides more transmission path than the fixed one.

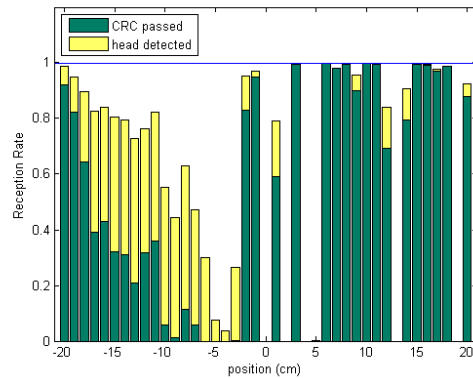

(a) Sensor node on stator

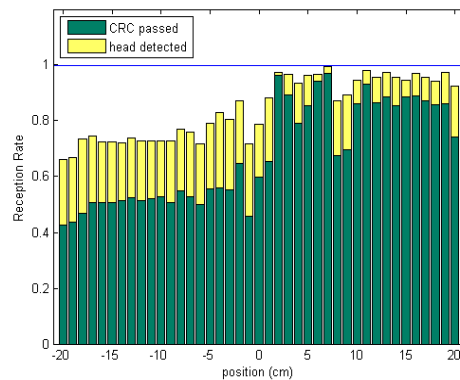

(b) Sensor node on shaft

Fig. 9 Fading effect observation

accelerometer chip from Analog Device, Inc. A 3V DC power supply and a data acquisition device are used for this evaluation board. This accelerometer has a sampling rate of 100Hz. Figure 10 (a) shows the spectral analysis of three accelerometer sensors on the side box. Figure 10 (b) and (c) shows the spectrum of each wired sensor outside compared with wireless sensor inside the motor. The motor is running at 900 rpm (15Hz). The spectrum clearly shows the main frequency peak and other

unknown contents. The wired accelerometer has lowest noise level because of its higher sampling rate. As can be seen their frequency spectrums match very well. The wireless sensor spectrum has a slight frequency shift due

to small sampling rate and short data collection period. It can be improved by changing the sampling rate and by taking longer recording time period.

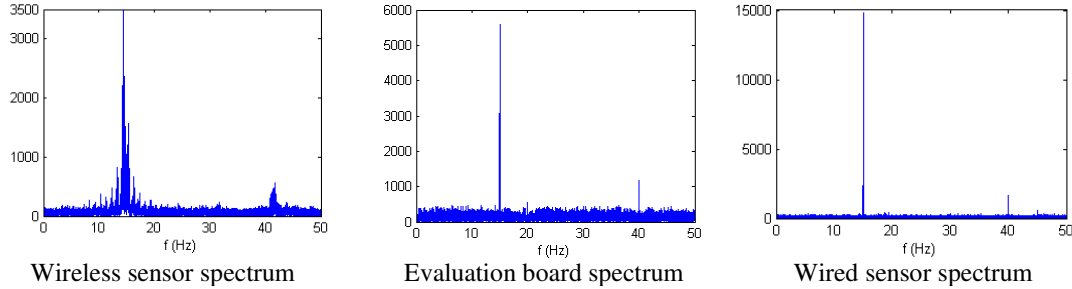

(a) Three sensors on side box

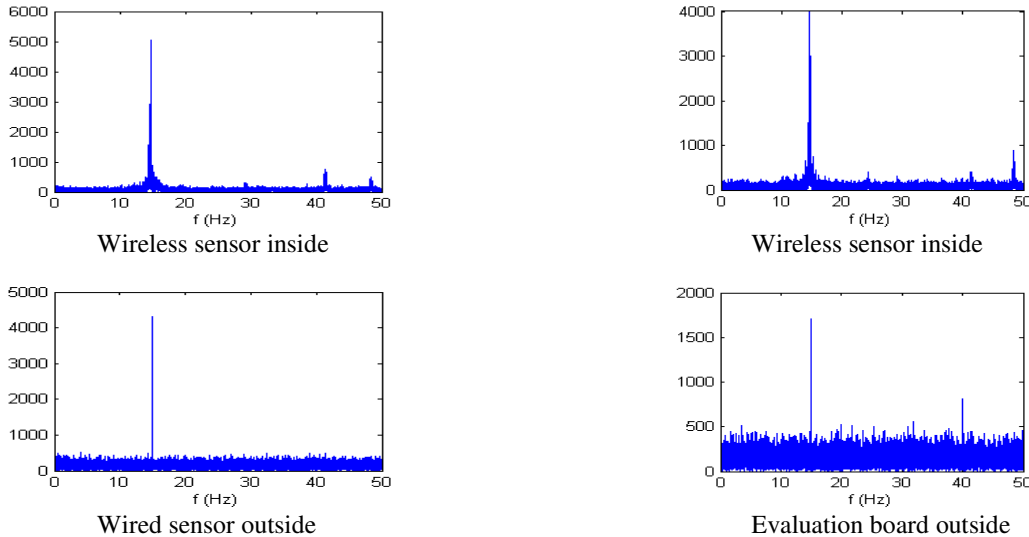

(b) Compared with wired accelerometer

(c) Compared with evaluation board

Fig. 10 vibration sensor frequency analysis

## II. CONCLUSIONS

In this paper, we have described results from a collection of vibration measurement experiments designed to demonstrate the feasibility of wireless sensors for health monitoring in small induction motors. The wireless sensor node inside the motor can always send out signals to the base station outside in a 0.6m circular region. For totally enclosed motors, the side box side has always some parts without metal. At some points even as far as 2.5m, the packet delivery performance is also satisfactory. The battery under very high transmitting load can last as long as 40 hours. The packet delivery performance does not show clear difference along most

of the battery lifetime. Due to multi-path propagation phenomenon, there are some null points where the signal gets canceled. The position has to be adjusted to find the position of high reception. Vibration data from the wireless sensor shows a promising accuracy of frequency spectrum comparable to the more reliable wired sensors. Battery life is a limiting factor in the application of wireless sensor technology. As the battery degrades, performance deteriorates. The most power-intensive aspect of the operation of these nodes is the communication. If communication is reduced by on-board processing of the measured data, then the battery life can be lengthened considerably. These experiments will be extended to study the performance of wireless sensors in large induction

motors. One attractive aspect of the wireless nodes is that they can accept measurements from several sensors. They can also perform local computations and signal processing. This feature further reduces the transmission load and extends the life of the battery. Finally, wireless sensors are low power devices and can be powered by energy scavenging methods from available environmental sources such as vibrations and magnetic fields.

#### ACKNOWLEDGEMENTS

The authors would like to thank Wallace Brithinee, Donald Brithinee and Bill Butek of Brithinee Electric Inc. located in Colton, California, for their support with equipment and expertise.

#### REFERENCES

1. B.K.N. Rao. Handbook of Condition Monitoring, Elsevier Advanced Technology, UK, 1996.
2. Jerry Zhao, Ramesh Govindan, Understanding packet delivery performance in dense wireless sensor networks, *SenSys'03*, November 5-7, 2003, Los Angeles, California, USA.
3. D. Ganesan, B. Krishnamachari, A. Woo, D. Culler, D. Estrin, and S. Wicker. Complex Behavior at Scale: An Experimental Study of Low-Power Wireless Sensor Networks. In Technical Report UCLA/CSD-TR 02-0013, Computer Science Department, UCLA, July 2002.
4. Tsai, H.M. et al. Feasibility of In-car Wireless Sensor Networks: A Statistical Evaluation. 2007 4<sup>th</sup> Annual IEEE Communications Society Conference on Sensor Mesh and Ad Hoc Communications and Networks, pg: 101.
5. Paselli, Michele, et al. A High-performance Wireless Sensor Node for Industrial Control Applications. In Proceedings: IEEE 3<sup>rd</sup> International Conference on Systems, 2008.
6. Rahimi, M., Shah, H., et al. Studying the feasibility of energy harvesting in a mobile sensor network. In Proceedings: ICRA'03, IEEE International Conference on Robotics and Automation, 2003.
7. K. Jemielniak, Commercial Tool Condition Monitoring Systems, International Journal of Advanced Manufacturing Technology, 15:711-721, 1999.
8. "Intelligize Your Process", ARTIS company presentation, Germany, 2007.
9. "Process Control During Grinding and Dressing", brochure of NORDMANN Company, Germany, 2004.
10. "PROMOS for grinding and dressing", brochure of PROMETEC Company, Germany.
11. Discenzo, Fred M; Chung, Dukki; Loparo, Kenneth A. Pump Condition Monitoring Using Self-Powered Wireless Sensors. *Sound and Vibration*, 40(5): 12-15, 2006.
12. Xingfa Shen, W. Zhi, and S. Youxian. Wireless sensor networks for industrial applications. In proceedings: Intelligent Control and Automation, 2004. WCICA 2004. Fifth World Congress on. 2004.
13. Bonivento, A., L.PI Carloni, and A. Sangiovanni-Vincentelli. Platform-based Design of Wireless Sensor Networks for Industrial Applications. In Design, Automation and Test in Europe, 2006. DATE'06. Proceedings. 2006.
14. Xin Xue, Luis Gonzalez-Argueta, V. Sundararajan. Energy Scavenging For Wireless Sensor Networks. In proceedings: 2007 IDETC, ASME/IEEE International Conference on Mechatronics and Embedded Systems and Applications, Las Vegas, USA, Sept. 4-7, 2007.
15. Audrey Wood, Magnetic Venture: The Story of Oxford Instruments, Oxford University Press, USA, 2001.
16. D. Gay, P. Levis, R. von Behren, M. Welsh, E. Brewer, and D. Culler. The nesC language: A holistic approach to networked embedded systems, in Proceedings of the ACM SIGPLAN 2003 conference on Programming Language Design and Implementation, pp. 1-11, ACM Press, New York, June 9-11, 2003.

**Xin Xue** is a graduate student in the Department of Mechanical Engineering at the University of California, Riverside. Her research interests include condition monitoring, sensor networks, sensor fusion, energy harvesting. She received her BS in mechanics and engineering science from Fudan University. Contact her at A108 Bourns Hall, Univ. of California, Riverside, Riverside, CA 92507, [xxue@engr.ucr.edu](mailto:xxue@engr.ucr.edu)

**V. Sundararajan** is a faculty member in the Department of Mechanical Engineering at the University of

California, Riverside. His research interests include sensor networks, environmental monitoring, energy harvesting, computational geometry, collaborative processing, and manufacturing systems. He received his MS and PhD in mechanical engineering from UC Berkeley. Contact him at A317 Bourns Hall, Univ. of California, Riverside, Riverside, CA 92521; [vsundar@engr.ucr.edu](mailto:vsundar@engr.ucr.edu)